



Series Belt Sampler

FOR NEW OR EXISTING APPLICATIONS

Safe, Accurate Sampling from Moving Conveyors



Introducing JBLCo's newly designed product sampler, the QC-360. This quality control sampler developed, primarily, for the Aggregate Industry, will allow for the collection of reliable results for quality control purposes.

FEATURES INCLUDE:

- ▶ Electric drive integral mounted gear reducer
 - ▶ Low maintenance/Few moving parts
 - ▶ Central lubrication
 - ▶ Eliminate the need for manual "Grab" samples and increase Employee Safety
 - ▶ Save Time and Money by keeping your conveyor on the move
 - ▶ Increase Sample Accuracy and reduce Out-Of-Spec Product
 - ▶ Backed by full time Sales, Engineering, Service & Parts Departments
- ▶ Sample Discharge at sampler or ground level with optional chute work
 - ▶ Optional Controls remotely mounted or at sampler



- ▶ QC-360 sampler wired for Customer Supplied Controls or optional PLC Controls are available. (Deluxe Timed Controls Illustrated)

QC-360 SYSTEM INCLUDES:

- ▶ Base Machine
- ▶ Divider/ Cutter Assembly
- ▶ Standard Drive
- ▶ Alarm Horn & Junction Box
- ▶ NEMA 4-TEFC Motor
- ▶ Gray Paint Scheme
- ▶ (1) O&M Manual



Quality Control Sampler

JBLCo

QC-360 Quality Control Sampler QC-360 Quality Control Sampler QC-360

Heavy Duty Electric Drive

**Easily Removable Covers-
for Easy Maintenance**

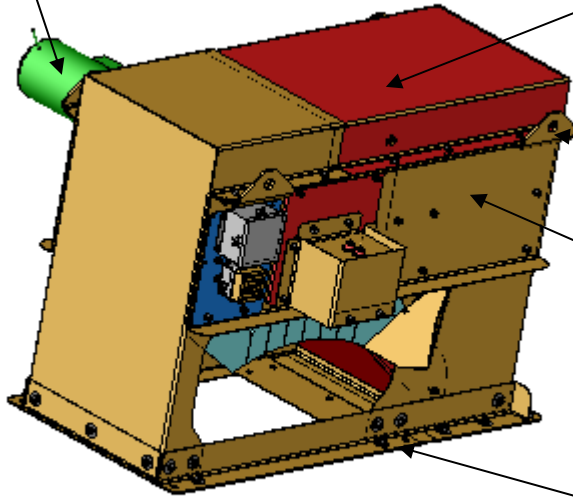

Lifting Lugs

**Heavy Steel Housing-
for Long Life**

Easily Bolted Directly to Conveyor Frame



THE QC-360

SAFE & ACCURATE SAMPLING

THE PROFESSIONAL WAY!!

QC-360 MODEL No.	BELT SIZE	HP
QC-360/24	24"	3HP
QC-360/30	30"	5HP
QC-360/36	36"	7.5HP
QC-360/42	42"	10HP
QC-360/48	48"	12.5HP

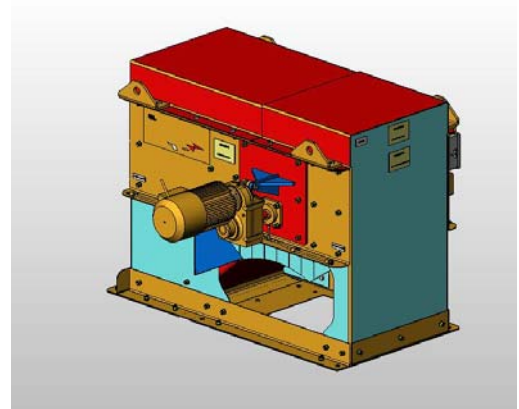

For more information, contact your local JBLCo Sales or Technical Service Representative to receive a thorough review of your application and prompt development of a sales quotation specifically suited to your needs.

JOHN B. LONG Co
 1040 Dutch Valley Dr. • Knoxville, Tennessee 37918 U.S.A.
 Phone (865) 522-8686 • Fax (865) 523-4996
 Website: www.jblco.com • Email: sales@jblco.com
 Engineered and manufactured in the U.S.A.



QC-360 Quality Control Sampler QC-360 Quality Control Sampler QC-360